



Design of an Intelligent Broken Window System for Dealing with Bus Fire Accidents

Shuman Guo^{1*} and Henglei Li¹

¹*School of Mechanical Engineering, North China University of Water Resources and Electric Power, Zhengzhou, 450045, China.*

Authors' contributions

This work was carried out in collaboration between both authors. Author HL designed the study, performed the statistical analysis, wrote the protocol and wrote the first draft of the manuscript. Authors SG and HL managed the analyses of the study. Author HL managed the literature searches. Both authors read and approved the final manuscript.

Article Information

DOI: 10.9734/JSRR/2020/v26i930315

Editor(s):

(1) Dr. Prinya Chindaprasit, Khon Kaen University, Thailand.

Reviewers:

(1) Oyebola Blessed Olalekan, Gateway (ICT) Polytechnic Saapade, Nigeria.

(2) Oyelakin K. Akinloye, Federal University of Technology, Nigeria.

Complete Peer review History: <http://www.sdiarticle4.com/review-history/63270>

Original Research Article

Received 28 September 2020

Accepted 04 December 2020

Published 19 December 2020

ABSTRACT

In recent years, bus fires occur frequently and accidents are often accompanied by serious casualties. Aiming at this situation, in order to improve the shortage of the traditional way of escape for bus and reduce casualties, in this paper, an intelligent escape system for bus through broken Windows was designed. The system adopts modular design, and a large number of experiments and optimization are carried out in dangerous goods early warning, fire detection and broken window effect test. The results show that the system can effectively break windows and quickly open up multiple escape routes in the case of bus fire accident.

Keywords: Intelligent broken window system; sensor; S9S12GN48.

1. INTRODUCTION

With the rapid development of social economy and the acceleration of urbanization, intercity bus

has become an indispensable mode of transportation for residents. However, the frequent occurrence of bus fire accidents also seriously affects the safe operation of urban

*Corresponding author: E-mail: 461853800@qq.com;

traffic system, causing significant personal safety and property losses to passengers and also posing a threat to social stability. At present, the main escape routes of passenger cars in traffic accidents include: door, safety roof window, emergency window hammer to break glass [1]. But in an emergency, the crowd panic, it is easy to cause congestion. Inability to open doors effectively. The design of safety roof window is narrow, high position and difficult to open. It is only suitable for vehicle rollover and it is difficult to achieve the purpose of escape in case of fire. The emergency hammer is a tool used to break the emergency window and open an escape route. Although it is considered to be the most effective tool for opening the escape route, the quality of such products in the market is very different and even the majority of passenger cars have safety hammer missing or unequipped phenomenon. Secondly, the escape personnel need to make proper efforts to achieve the purpose of breaking the window, In the case of panic and even in smoky situations, it is almost impossible for them to break the window and escape within the effective time of escaping. In order to ensure that passengers can escape successfully in case of bus fire accident, an intelligent bus automatic window breaking system is designed to make up for the deficiency of the traditional way of window breaking.

2. THE OVERALL DESIGN SCHEME OF THE SYSTEM

The intelligent broken window escape system mainly includes flammable and explosive gas sensor, laser smoke sensor, intelligent main control module, broken window actuator, manual switch and so on [2,3]. The core of the intelligent broken window escape system adopts Freescale S9S12GN48 [4] microcontroller as the main part of the control device. When the sensor detects that there are combustible and volatile dangerous goods in the vehicle or there is a fire,

the signal is transmitted to the intelligent main control module [5]. The main control module can display the sound and light alarm at the corresponding position according to the sensor information to remind the driver to deal with it. The driver can press the manual window breaking button to send instructions to the window breaker of the execution unit. After the window breaker installed on the glass receives the signal, the window breaker sends out a probe to break the glass. The intelligent window breaking escape device also has the function of automatic window breaking. If the driver is injured or unable to operate the button for other reasons, the system can automatically start the window breaking function after the set time (set N seconds as required) to quickly open the escape channel. In order to deal with the occurrence of false alarm, the system also has a false alarm reset key to prevent property loss caused by false alarm.

3. SYSTEM HARDWARE DESIGN

The hardware part of the system includes inflammable and explosive gas sensor and laser smoke sensor module, intelligent main control module, broken window actuator module, power management module. The power management module is connected with each module to provide each module with appropriate working voltage and current.

3.1 Power Management Module

The system uses 12V battery as the main power supply. 12V stable DC (Direct current) voltage is used to supply power to the broken window execution module and 5V stable DC voltage is generated by the step-down circuit to supply power to the flammable and explosive gas sensor module, laser smoke sensor module and intelligent master control module [6].

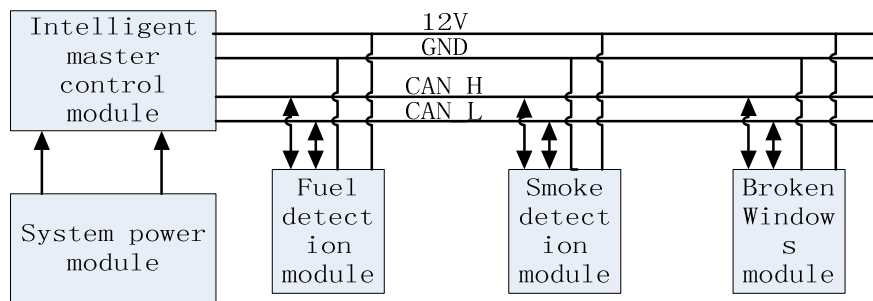

Fig. 1. Schematic diagram of working principle of the system

As shown in Fig. 2, the step-down circuit selects the TPS5430DDAR step-down module. The input voltage is 12V, which is filtered into TPS5430DDAR by capacitor filter and then output stable 5V voltage through voltage stabilizing filter to supply power to the main controller module and sensor module.

3.2 Sensor Module

3.2.1 Smoke sensor module

The bus broken window system requires higher accuracy, real-time and reliability of smoke alarm sensor. Therefore, ZH30B laser dust smoke sensor is used to monitor the fire information. As shown in Fig. 3, the core of smoke sensor module is ZH03B laser dust smoke sensor. The module has dual signal output, including PWM (Pulse-Width Modulation) and serial port. In this system design, only PWM output of the module is used, and the serial output pin is idle.

3.2.2 Flammable and explosive gas sensors

The ZPE02 flammable and explosive gas sensor used in this system has high sensitivity to flammable and explosive gas in a wide concentration range, strong anti-interference ability, low power consumption, quick response recovery, simple detection circuit, good stability, long life and other advantages. It is mainly used in the detection of flammable and explosive gases in the car compartment and other places. The types of gases that can be detected include alcohol, methane, gasoline, propane, etc. The output voltage is 0 ~ 4.9 V, which can be directly connected to the analog input channel of S9S12GN48 MCU.

3.3 CAN Communication Module

The communication between the intelligent main control module and the window breaker executive module is carried out through CAN (Controller Area Network) network. In order to realize CAN communication, two special chips are needed: CAN controller and CAN transceiver [7]. This system uses S9S12GN48 chip integrated CAN controller, only need to choose a CAN transceiver. TJA1042T CAN transceiver which is widely used in automobile industry is selected in this system. It has good electromagnetic compatibility and the transmission rate is as high as 5mbit / s. CAN interface circuit is shown in the figure.

3.4 Broken Window Actuator Module

The mechanical window breaking device used in this system is rated working voltage of 12V. When it is necessary to break the window, the single-chip microcomputer outputs a high level to enable IF7341MOS tube to conduct [8]. At this time, the electric window breaker returns to conduct and pushes the broken window probe to complete the action of breaking the window.

3.5 Overall System Circuit

The circuit connection of each module of the system is shown in the figure above. The PWM pin of smoke sensor module is connected with pp6 interface of MCU S9S12GN48 and pins RXD and TXD of flammable and explosive gas sensor are connected with analog TXD and RXD interface of S9S12GN48. Out_H、M、L are connected with analog GPIO interface of S9S12GN48. The opening of mechanical window breaking module is controlled by MOS tube. The fire alarm information can communicate with intelligent main control module through plug P4.

4. SYSTEM SOFTWARE DESIGN

4.1 Intelligent Main Control Module

The program flow chart of intelligent main control module is shown in Fig. 7:

System power on initialization, initialization of each function module registers, parameters, etc. Then the fault diagnosis is carried out to diagnose whether the ROM, RAM and actuator of the system are faulty [9]. If there is a fault, the corresponding treatment measures are taken according to the type and severity of the fault. After that, the level state of the demand port of the window breaking button is detected to determine whether to break the window, and the information is sent to each window breaking actuator module through CAN communication. If the window is to be broken, the buzzer driving signal is output, and the corresponding light color driving signal of tricolor LED is output according to the normal, fault and broken window status of the system.

4.2 Broken Window Module

The system program block diagram is shown in Fig. 8.

The system is powered on for initialization and fault diagnosis and corresponding treatment measures are taken according to the type and severity of the fault. After the system in normal condition, the CAN message received is analyzed to analyze whether it is necessary to break the window. If it is necessary to break the window, the drive signal of the window breaker is output. If there is no need to break the window, a cycle ends. The software design of the system is divided into two task functions.

The first function is to monitor the internal environment of the carriage through flammable and explosive gas sensors to determine whether there are inflammable and explosive dangerous

goods; the second function is to monitor the compartment through the smoke sensor, which will timely upload the fire alarm to the intelligent main control module in case of fire. In task 1, the smoke sensor collects smoke signal in real time and transmits it to the analog signal input port of S9S12GN48 through signal conditioning circuit and converts analog signal into digital signal through A/D conversion [10]. Compare the smoke digital quantity with the set danger threshold. If it is higher than the danger threshold, can alarm message will be sent to the intelligent main control module and the intelligent main control module will decide whether to perform window breaking action. Task 2 is similar to task 1.

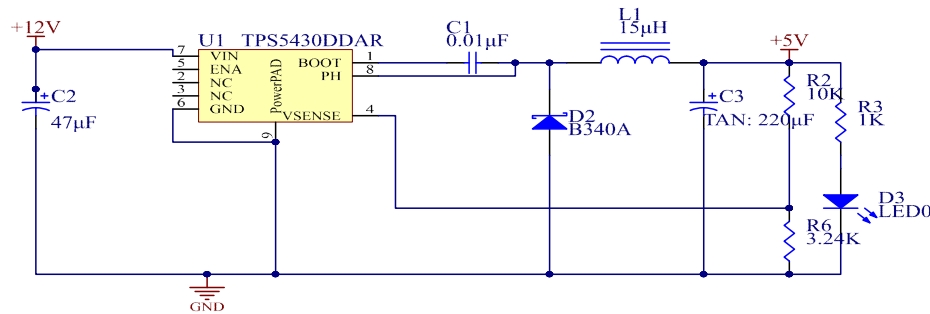

Fig. 2. Step-down circuit

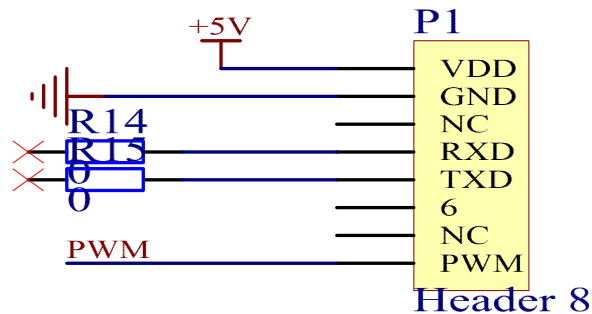

Fig. 3. Smoke sensor module circuit

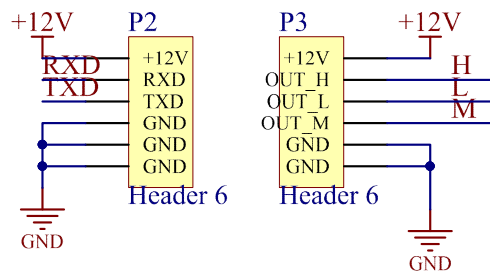

Fig. 4. Flammable and explosive gas detection sensor

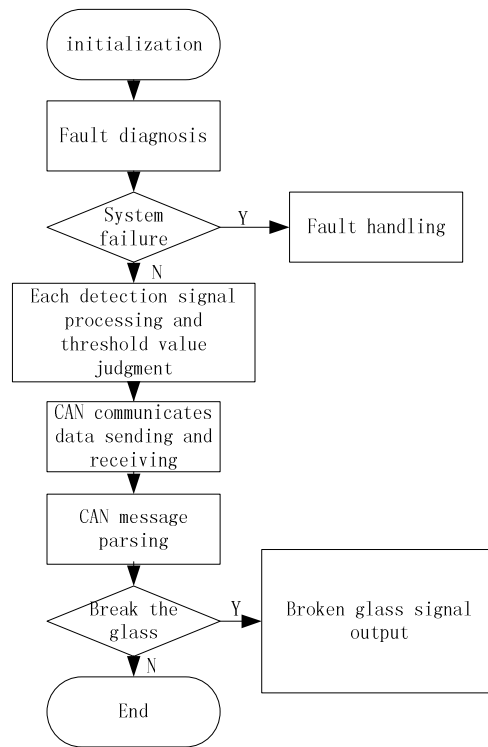

Fig. 8. Module of glass breaking actuator

5. CONCLUSION

The intelligent glass breaking and escape system based on S9S12GN48 designed in this paper relies on S9S12GN48 microcontroller and through the integration of several modules, designs a system that can automatically detect the environmental information of the vehicle, such as a fire accident can automatically break the glass to help passengers escape. The system has been verified by practical test and the test data meet the design requirements. The test results show that the system can work stably and effectively. It lays a foundation for the follow-up vehicle matching and promotion application. The mechanical window breaking module of this system can be improved, such as using blasting method to break Windows, which can save space and react more quickly. At the same time, the intelligent escape system designed in this paper can also open the escape route for passengers in the shortest time when the bus encounters other situations, such as the driver's coma and the vehicle falling into the water.

ACKNOWLEDGEMENTS

This project is supported by the Science and Technology Research project of The Department

of Science and Technology of Henan Province, China: Research on key technologies of automatic window breaking and Escape System of Vehicle Fire accident based on image recognition technology (182102310716)

COMPETING INTERESTS

Authors have declared that no competing interests exist.

REFERENCES

1. Chao, Wang, et al. "Design of Intelligent Broken Window Escape System Based on Arduino." *Automation & Instrumentation*; 2017.
2. Min Li. "The Design of SMS Alarm System on CORTEX M3 + SIM900A." 2016 International Conference on Robots & Intelligent System (ICRIS) IEEE; 2016.
3. Gang, and Wu. "The Design of the Gas Alarm System Based on Microcomputer; 2018.
4. Xiaowei, Liu L. Tianci and L. Shunzhang . "A Design of Control System of DC Charging Pile Gun Based on MC9S12." *The World of Inverters*; 2017.

5. Mahzan NN, et al. "Design of an Arduino-based home fire alarm system with GSM module." Journal of Physics Conference 1019(2018):012079-
6. Xiang, Zhang. "Design and analysis of digital circuit automatic test system based on GPIB." Electronic Design Engineering; 2019.
7. Jia-Dong, Bao, and H. Qiang . "Application of CAN Bus in Vehicle Window Lifter Motor Comprehensive Testing System." Automation & Instrumentation; 2018.
8. Ke-Wen WU. "Designing of the Step-down DC Switch Regulated Power Supply." Journal of Wuhan Institute of Shipbuilding Technology; 2017.
9. Sun, Miao Zhong SH. Cui, BF Tan. Design of an experiment rig for traffic light control system based on freescale MCU. Materials, Manufacturing Technology, Electronics and Information Science (MMTEI2015): Proceedings for the 2015 International Workshop on Materials, Manufacturing Technology, Electronics and Information Science (MMTEI2015).
10. Xikun Lu, et al. "Design of Intelligent Alarm System for Fire Based on Microcontroller." Electronic Test; 2018.

© 2020 Guo and Li; This is an Open Access article distributed under the terms of the Creative Commons Attribution License (<http://creativecommons.org/licenses/by/4.0>), which permits unrestricted use, distribution, and reproduction in any medium, provided the original work is properly cited.

Peer-review history:

*The peer review history for this paper can be accessed here:
<http://www.sdiarticle4.com/review-history/63270>*