



Design of Intelligent Environment Monitoring System Based on CAN Bus

Yang Jie^{1*}, Li Yuanyuan¹, Huang He¹ and Wu Han¹

¹*School of Electrical and Electronic Engineering, Shanghai University of Engineering Science, Shanghai, 201620, China.*

Authors' contributions

This work was carried out in collaboration between all authors. Author YJ designed the circuit and hardware platform. Author LY managed the guidance and inspection. Authors HH and WH are responsible for the design of software programming and wrote the first draft of the manuscript and managed literature searches. All authors read and approved the final manuscript.

Article Information

DOI: 10.9734/BJAST/2016/22521

Editor(s):

- (1) Giovanni Bucci, University of L'Aquila, Italy.
- (2) Rodolfo Dufo Lopez, University of Zaragoza, Spain.

Reviewers:

- (1) Kalpana L. Chaudhari, Shah and Anchor Kutchhi Polytechnic, Mumbai, India.
- (2) Nikos Petrellis, Technological Educational Institute of Thessaly, Greece.
- (3) Rajinder Tiwari, Amity University, Lucknow, India.

Complete Peer review History: <http://sciencedomain.org/review-history/12767>

Original Research Article

Received 6th October 2015
Accepted 11th December 2015
Published 22nd December 2015

ABSTRACT

This article aims at the college students' innovative project, which realizes the intelligent environment's monitoring system. It makes the design of hardware platform, which is based on CAN bus and the embedded system. It receives environmental information through sensors, and uses CAN bus to transmit signals to the embedded system for analysis and processing. It can realize the intelligent of the environment's monitoring system, and improve the accuracy of monitoring in many aspects.

Keywords: CAN bus; environment's monitoring system; embedded system; transmit signals.

1. INTRODUCTION

In recent years, the digital control of analog video surveillance and digital video surveillance

products were introduced in the domestic and foreign markets. Front-end integration, digital video, network monitoring and integrated systems are the development direction of video

*Corresponding author: E-mail: yangjiefuture@163.com;

surveillance system. The network is the basis for system integration, so that the development features of the two video surveillance are characterized by digitization and networking [1-2]. Therefore, the article introduces an intelligent environment monitoring system based on CAN bus, which is set by the platform of embedded system and CAN bus. CAN bus servers as sharing information and resources. The data communication on CAN bus improves the system reliability, promptness, flexibility, maintainability, and a better matching and coordination of the various control systems. And CAN bus communication is characterized by a high speed, high reliability, easy connection, a simple multi-master communication protocol, and so on. It makes our study bustling with life [3-4]. The detection circuit in the article is designed independently and it has advantages in a fast respond and accurate measurement.

2. THE BASIC PRINCIPALS AND DESIGN IDEARS

2.1 The Basic Working Principle

The article, our team use photosensitive, temperature and humidity sensors to collect environmental information and transmit data via CAN bus to the embedded system to analysis and process. The results will be displayed on the LCD screen. It will alarm when the output value threshold is exceeded, which enables to keep the unmanned environmental intelligent monitoring working.

2.2 Design Ideas

The system is designed with two boards. One works as the control board, while the other works as a detection board. Infrared remote controller is used to input the thresholds in the environment control board. The detection board uses sensors to acquire and display the real-time environment information and transfers the collected data via CAN bus to the control board. The control board analysis, discriminates and displays the received data. So it can realize a concentrated management and distributed control.

3. THE DESIGN OF HARDWARE

3.1 The Hardware Design of the System

3.1.1 Embedded system STM32

Figs. 2 and 3 are the STM32 embedded system function base plate and the MCU principle

diagram that used in the paper. STM32F103RBT6 is selected as the MCU, which has 64-pin, program memory 128K, 51 I/O ports. It has a low price but a high quality, fully configured. As a main control system, STM32 can receive the environment threshold, which is set via infrared remote controller, and receive, discriminate and analysis CAN bus data. Finally the monitor board is commanded to show the current environment information and alarms when real-time environment exceeds the threshold we set in advance [5-7].

3.1.2 CAN bus module

Fig. 1 shows a block diagram of a hardware board SJA1000 CAN bus module that is used herein. The 8core module of CAN bus is responsible for transmitting and receiving the information frame and realizing CAN protocol. The interface management logic is responsible for interfacing with external host controller, in the unit, each register can be accessed by the master controller via SJA1000's address / data bus. Sending buffer can store a complete message frame, whose length is 13 bytes. The main controller identifier and the data can be fed into the transmit buffer directly. Then set the command register (CMR) of the transmission request bit TR, start the CAN core module to read the data in the buffer. At last, the data is encapsulated into a complete CAN message frame according to CAN protocol, and sent it through the transceiver to the bus.

3.1.3 Monitoring module

Fig. 2 is a circuit diagram of the monitoring module, including temperature sensor DS18B20, humidity sensor DHT11, the light detection circuit and power regulator module. When it comes to temperature section, the digital temperature sensor DS18B20 uses single-bus mode and it needs only one I/O port to keep communicating with MCU, and temperature range is 55~125^{°C}. Each DS18B20 has a unique chip serial number, so you can simultaneously connect multiple DS18B20 on a single wire bus, Then it can put multiple temperature sensor in many different places, which can facilitate the use of CAN bus and the temperature measurement. And a method for supplying power to the DS18B20 is to access external supply from VDD pin (Fig. 3), so that the I/O line is not necessary to strengthen. A bus controller will not always be kept at a high level during the temperature conversion. During conversion can also allow other data to

exchange on single-wire bus. In addition, the single-wire bus can be linked to any number of chip DS18B20, and if it uses an external power supply, it can send a Skip ROM command first,

following by a Convert T command. So that they can also perform a temperature conversion. Therefore, it will be more convenient for connecting and detecting temperature sensor [8].

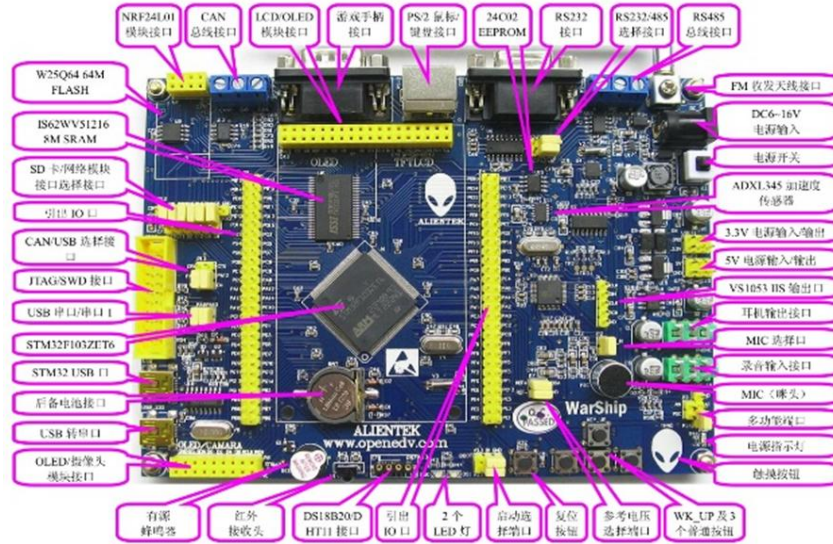

Fig. 1. Function backplane

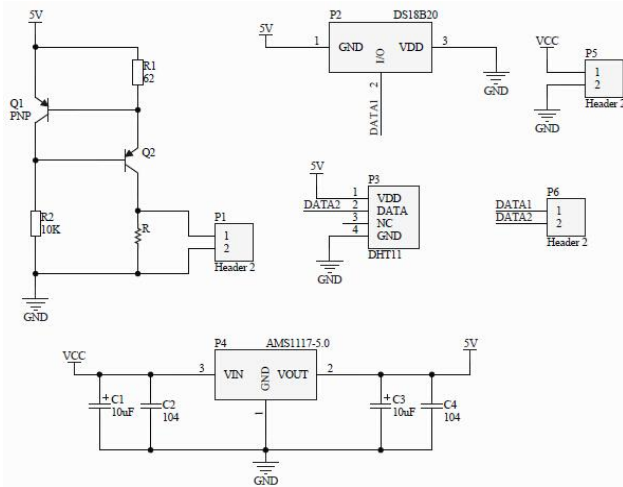

Fig. 2. Circuit diagram of the monitoring module

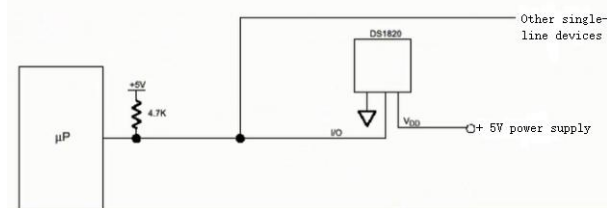

Fig. 3. DS18B20 powered mode

In humidity measurement part, a digital humidity sensor DHT11 is chosen, also with single-bus structure, which has a humidity measurement range of 20 to 90%. DHT11 humidity sensor uses digital modules collection technology and the humidity sensor technology. Therefore it can ensure that the sensor has a very high reliability and excellent long-term stability. The specific working principle is that when the MCU sends a start signal, DHT11 is transferred from a low-power mode to the high speed mode and waiting for the end of the start signal MCU. Every time when DHT11 sends the appropriate signal and 40bit data, meanwhile it triggers a signal acquisition. Then it chooses the received data through the MCU. If it doesn't received the start signal that sent by the MCU, DHT11 will not be positive to collect humidity and stay low-speed mode after collecting the data [9]. Light intensity detection section. Actually it is a constant current source circuit. And it also connected constant current circuit with the photoresistor. When the light intensity changes, the resistance value of the photoresistor will change, and when constant current flows, the photosensitive voltage that across the resistor will also changes. After that the voltage is sent across the resistor into STM32, and calculated by the software, we can get the value of the corresponding light intensity. The article will set the level of light intensity through the program. In a dark room, with a 60W incandescent lamp, then put the module in the distance of 0 m, 1 m, 2 m 19 m away from the light, and detect voltage value at these distances. And the light intensity levels are classified after the environmental test [10-12].

In the power module part, ASM1117-5.0 is used to regulate the voltage into linear, which ensures the voltage of detection circuit that it meets the requirements.

Fig. 4 is the front part of monitoring PCB board module.

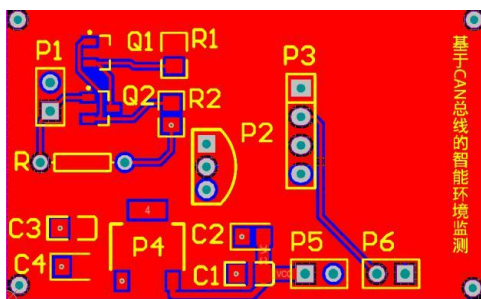

Fig. 4. The front part of PCB

Fig. 5 is the back part of monitoring PCB board module.

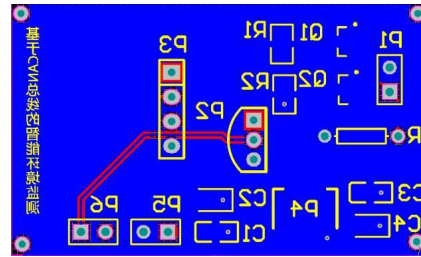

Fig. 5. The back part of PCB

Fig. 6 is a part of 3D map of the PCB.

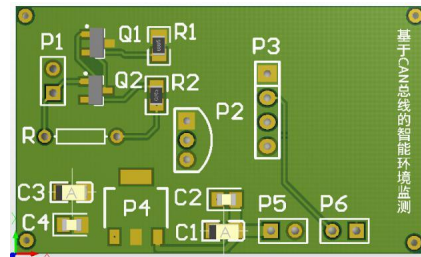

Fig. 6. 3D map of PCB

4. THE DESIGN OF SOFTWARE

There are 2 kinds of programs, one is for the detection board and another is for the control board.

Program flow chart is as follows:

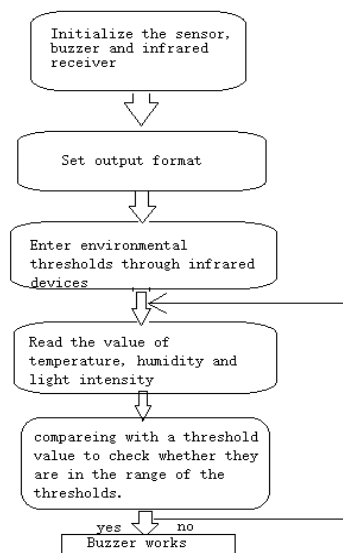

Fig. 7. Program flow chart

4.1 The Program for the Main Board

```

#include "led.h"
#include "delay.h"
#include "key.h"
#include "sys.h"
#include "lcd.h"
#include "usart.h"
#include "can.h"
#include "beep.h"
int main(void)
{u8 canbuff[8];
u8 key;
u8 i=0;
u8 mode=0;
delay_init();//Initialize time delay function
NVIC_PriorityGroupConfig(NVIC_PriorityGroup_2);//Set the interrupt priority group as group 2 ,2 bit to take
priority, 2 bit to response to a priority
uart_init(115200); //gorge Initialize to115200
LED_Init(); //initialize the hardware interface's connection with LED
LCD_Init(); //initialize LCD
BEEP_Init();//initialize Beep
CAN_Mode_Init(CAN_SJW_1tq,CAN_BS2_8tq,CAN_BS1_11tq,4,CAN_Mode_LoopBack);//initialize CAN's baud
as 500 Kbps
POINT_COLOR=RED; //Set the font in red
LCD_ShowString(30,50,200,16,16,"environmental monitoring");
LCD_ShowString(30,70,200,16,16,"received by CAN BUS");
LCD_ShowString(30,90,200,16,16,"Lsens,Temp,Humi");
LCD_ShowString(60,130,200,16,16,"Receive Mode");
LCD_ShowString(60,150,200,16,16,"Receive Data:");//show the information
POINT_COLOR=BLUE;//Set the font in blue
while(1)
{CAN_Mode_Init(CAN_SJW_1tq,CAN_BS2_8tq,CAN_BS1_11tq,4,mode);//set CAN as transmission mode and
initialize CAN's baud as 500 Kbps
POINT_COLOR=BLUE;//Set the font in blue
key=Can_Receive_Msg(canbuff);
if(key)//if received data
{LCD_Fill(60,170,130,310,WHITE);//clear the data showed before
for(i=0;i<key;i++)
{if(i==0) { LCD_ShowxNum(60+i*32,170,canbuff[i],3,16,0X80); //show the illumination intensity
LED0=!LED0;delay_ms(250); }
if(i==1)
{LCD_ShowNum(60+32*i,170,canbuff[i],3,16);//show the temperature
delay_ms(10);;}
if(i==2)
{LCD_ShowNum(60+32*i,170,canbuff[i],3,16);//show the humanity
delay_ms(10);;}
}}}}

```

4.2 System Debugging and Testing

The overall effect of the system shown in Fig. 8, the detection circuit module shown in Fig. 9.

First start up the system, then input the six environmental thresholds by infrared remote control. After that, the system begins to monitor and control board displays the data as shown in

Fig. 10. The monitoring board displays as shown in Fig. 11.

If the environmental conditions are normal, the display shows the real-time environmental conditions. When environmental conditions exceed thresholds, the beep will start to alarm. The condition that the data exceeds the threshold value is shown in Fig. 12.

An experiment was made to prove the accuracy and the reliability of the system.

Two measurers named humidity-temperature meter and light intensity meter are used in this experiment. They both have a better precision than the sensors that used in the intelligent environment monitoring system. Every two hours, in a drafty room, the temperature, humidity and light intensity are measured not only by the intelligent environment monitoring system, but also measured by the humidity-temperature meter and light intensity meter. Compared these figures in two different ways, our system is more accurate and reliable. It is also cheaper and smarter than the measuring instruments in the markets.

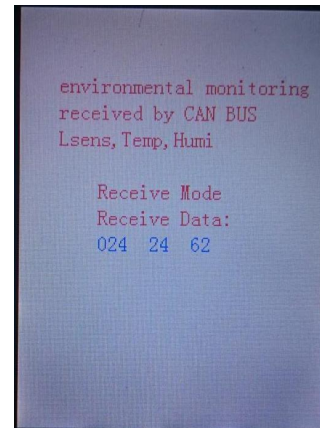

Fig. 10. Input the environmental threshold



Fig. 8. The overall effect of the system

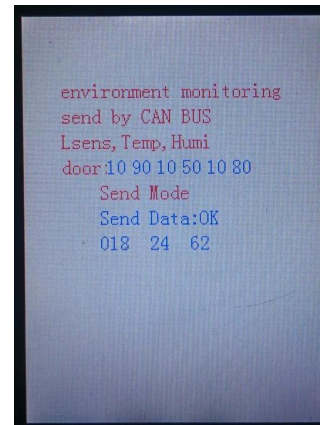

Fig. 11. Monitoring board display



Fig. 9. The detection circuit module

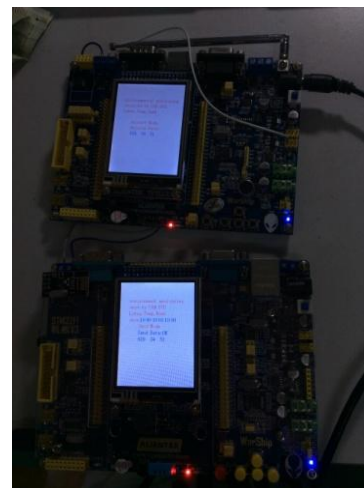

Fig. 12. Exceeds the threshold value

Time	6: 00	8: 00	10: 00	12: 00	14: 00	16: 00	18: 00	20: 00	22: 00
Accurate	15.5	19.3	22.7	25.8	28.4	25.9	21.1	18.8	16.9
Measured	15	19	23	25	28	26	21	19	17

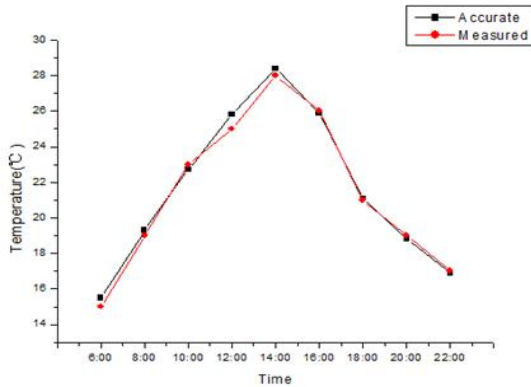

Fig. 13. The accurate and measured temperature results

Time	6: 00	8: 00	10: 00	12: 00	14: 00	16: 00	18: 00	20: 00	22: 00
Accurate	94.3	90.2	88.5	83.6	76.2	70.5	72.6	76.9	80.2
Measured	94	90	88	84	76	70	73	77	80

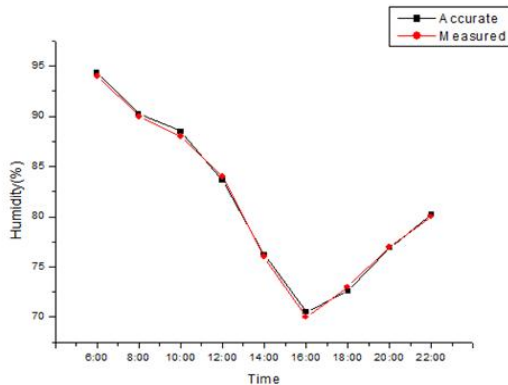

Fig. 14. The accurate and measured humid results

5. CONCLUSION

The article designed an intelligent environment monitoring system, which utilizes the embedded system as the core processor, and use CAN bus to transfer the data. It accepts the external environment information through the various sensors. By setting the threshold via the keyboard to achieve the purpose of intelligent monitoring environment. The Embedded system STM 32, which is economist and prevalent in the market make up the important part of the whole system and it is and easy to carry. The sensors referred here, have a good value of development.

The system enables to achieve a unmanned and intelligent environment monitoring. When the environment conditions exceed thresholds, the beep will go off. After testing the system, the system seems to be stable, reliable, and able to save human resources and the cost effectively. It has a practical value and social effects if they can be widely applied in granary and greenhouse or other places, which has a strict environmental requirements.

COMPETING INTERESTS

Authors have declared that no competing interests exist.

REFERENCES

- Hua Jing, He Huojiao, Yin Hua. Agricultural greenhouse environmental monitoring system based on WSN [J]. Agricultural Mechanization Research. 2013;11.
- Wang Jinhuan. The design of microcontroller greenhouse environment monitoring system [J]. High-tech Product Development. 2014;24(168) is based on: 12-13.
- Li Lianfang, Guo Xuesong. The embedded environmental radiation monitoring system based on CAN bus and Ethernet [J] Nuclear Electronics & Detection Technology. 2014;34(9):1148-1149
- Shen Yao, Li Xiaoqing, Zhou Yunfei. The design of Electric vehicle control system based on CAN bus [J]. Electronic Design Engineering. 2010;18(11):143-145.
- Wang Mingming, Wang Zhilin, Yuan Hao, Pan Hui. The practical granary temperature and humidity detection system based on MSP430 [J]. Modern Electronic Technology. 2012;02.
- Xie zhiying, Duan Rongxia, Li Ming. The intelligent lithium battery charger based on SP430 [J]. Industrial Control Computer. 2013;26(12):129-130.
- Peng Xiying, Zhao Qiangsong. The design of solar tracking system microcontroller based on Based Microcontroller AD1μC812 [J]. Mechanical Engineering and Automation. 2014;34(9):150-151.
- Liu Chang raw sensor Cookbook and application circuit: Temperature sensor Volume [M] Shaanxi: Xi'an University of Electronic Science and Technology Press; 2006.
- Chen Zhenlin, Cui Xinchun. The study of the accuracy in temperature and humidity

- sensors [J]. Measurement Technology. 2013;04.
10. Yun Zhonghua, Bai Tianrui. The indoor light intensity measuring instrument based on BH1750FVI [J]. Technology Aspect. 2012;6:27-28.
 11. Li Wenchen. The wireless environmental monitoring system based on Multi-sensor data fusion [D]. Nanjing University of Technology and Engineering; 2014. Design.
 12. Chen Musheng, Cai Zhishan. The design of GSM network and remote fire alarm system data fusion technology [J]. Quanzhou Normal University. 2014;32(6): 94-95.

© 2016 Jie et al.; This is an Open Access article distributed under the terms of the Creative Commons Attribution License (<http://creativecommons.org/licenses/by/4.0>), which permits unrestricted use, distribution, and reproduction in any medium, provided the original work is properly cited.

Peer-review history:
The peer review history for this paper can be accessed here:
<http://sciencedomain.org/review-history/12767>